

## ADDENDUM NUMBER 5

Date: 04/23/2026



**ARNOLD**  
DESIGN STUDIO

Project:

Project Location:  
**Harrisonburg, Virginia**

Commission No:

**Lineweaver Annex Renovation**  
**Glen's Fair Price Building – Adaptive Reuse**  
**JR Polly – Renovation**

**2119**  
**2504**  
**2505**

---

This Addendum, in its entirety shall become part of the record set of construction documents (project description, specifications, and/or drawings). All items are indicated by the corresponding portion of the construction documents. Please provide a copy of this addendum to all pertinent contractors to which the items apply. Any questions or clarifications regarding these items shall be directed to the Architect.

The following items shall be included within this Addendum.

### BIDDER QUESTIONS

1. Will you be sending out a Unit Price form to include with our bid for the 500 SF of drywall bulkheads?  
**AE Response - See attached revised Bid Form to include the drywall bulkhead allowance for Glen's Fair Price Building.**
2. E002 has a Lighting Control Sequence of Operation and Note 7 calls for daylight dimming controls.  
**AE Response – This note will be removed.**
3. On E503 the LCP detail appears to be incomplete. Please provide the make and model number of the Lighting Control Panel (LCP) along with its miscellaneous components such as the occupancy sensor, daylight sensor, switch controls. Please provide a diagram showing how the LCP connects to the sensors and light fixtures.  
**AE Response - The lighting control panel basis-of-design is provided in the notes of the lighting control panel detail. This lighting control panel will use an exterior photocell and an integral time clock to control the exterior lighting and the lighting for display room 102. All interior lighting will be**

**controlled with a variety of occupancy/vacancy sensors and room controllers as required.**

4. Please provide additional information regarding the scope of work for the Emergency Responder Radio Coverage  
**AE Response – The Emergency Responder Radio Coverage system can be deleted from the bid for Glen’s Fair Price Building.**

**SPECIFICATIONS – JR Polly Lineweaver**

1. See attached generator proposal and equipment specifications dated March 13, 2026

**CIVIL DRAWINGS**

1. No items.

**ARCHITECTURAL DRAWINGS – Glen’s Fair Price Building- Adaptive Reuse**

1. No items.

**PLUMBING DRAWINGS**

1. No items.

**MECHANICAL DRAWINGS**

1. No items.

**ELECTRICAL DRAWINGS**

1. No items.

**END OF ADDENDUM**

**BID FORM**

To: Harrisonburg Redevelopment & Housing  
Authority, 286 Kelley Street  
Harrisonburg, Virginia 22802

1. The undersigned, having become familiarized with the Specifications (including Invitation for Bids, this Bid form, the Contract, the General and Special Conditions, the General Scope of Work, the Technical Specifications, the Drawings, and Addenda, if any, as prepared by Arnold Design Studio and authorized by the Harrisonburg Redevelopment and Housing Authority, and on file in the office of Harrisonburg Redevelopment and Housing Authority, 286 Kelley Street, Harrisonburg, Virginia 22802, proposes to furnish all labor, materials, equipment and services required to construct and all site work, for the new construction of **Lineweaver, Glens Fair Price, and JR Polly Lineweaver** in accordance with all of the above documents , for the all-inclusive firm lump-sum of:

- 1. Base Bid -  
Lineweaver Annex \_\_\_\_\_ \$ \_\_\_\_\_ (Dollars)
- 2. Alternate 1 – add Glen’s Fair Price  
Building \_\_\_\_\_ \$ \_\_\_\_\_ (Dollars)
- 3. Alternate 2 – add JR Polly Lineweaver – Renovations  
\$ \_\_\_\_\_ (Dollars)
- 4. Bulkhead Allowance – 500 square feet of drywall bulkheads at 1’-0” deep  
from the ceiling for the Lower Level Floor Plan – Glens Fair Price Building  
\$ \_\_\_\_\_ (Dollars)

**LUMP SUM TOTAL** \_\_\_\_\_ \$ \_\_\_\_\_ (Dollars)

Proposed markup percentages for materials \_\_\_\_\_

2. The undersigned, understanding that time is of the essence in this project, proposes to complete all work required under this contract within \_\_\_\_\_ calendar days from the effective date of the contract or from the date when the notice to proceed was issued by the Contracting Officer whichever is later.

3. In submitting this bid, it is understood that the right is reserved by the Harrisonburg Redevelopment and Housing Authority to reject any and all bids. If written notice of the acceptance of this bid is mailed, or delivered to the undersigned within thirty (30) days after the opening thereof, or at any time thereafter before this bid is withdrawn, the undersigned agrees to execute and deliver a contract in prescribed form within ten (10) days after the contract is presented to him for signature.



## **PROPOSAL**

**PROJECT NAME: REDEVELOPEMENT AUTHORITY**

**BID DATE: 13 MARCH 2026**

---

**Work to be done at a Base Bid Price of \$190,058.00**

---

### **Scope of Work Excludes:**

- 1.** Temporary electric has been excluded.
  - 2.** Any and all rock removal for excavation/trenching has been excluded.
  - 3.** Any and all concrete demolition and repair has been excluded.
  - 4.** Any and all cutting, patching, or repair of drywall necessary for initial electrical installation has been excluded.
  - 5.** Any and all painting has been excluded.
  - 6.** Any and all tree trimming is excluded.
-

## Scope of Work Includes:

1. **Permits and Fees:** Included in the proposed price are all permits and fees necessary for the electrical installations as required by the authority having jurisdiction. This includes the electrical permit and street closure permit for the crane.
  2. **Demolition:** The Power Connection to provide the following demolition of the Project:
    - a. **400 AMP TRANSFER SWITCH**
    - b. **80 KW GENERATOR**
  3. **Distribution Equipment:** The Power Connection to furnish and install the following distribution equipment:
    - a. **400 AMP TRANSFER SWITCH**
    - b. **100 AMP TRANSFER SWITCH FOR FIRE PUMP**
    - c. **100 KW GENERATOR**

**\*\*\* THIS INCLUDES THE CRANE AND RIGGERS FOR THE DAY\*\*\***

**\*\*\*NOTE THIS IS A LIKE FOR LIKE, REMOVE AND REPLACE\*\*\*\*\***
  4. **Feeders:** The Power Connection to furnish and install all feeder conduits, conductors and appurtenances for all distribution equipment as indicated.
  5. **Conduit & Conductors:** The Power Connection to provide the following conduit and conductor installations:
    - a. Branch circuit wiring to be Type RMC.
    - b. Underground conduit to be PVC schedule 80.
    - c. Wire to be THHN
  6. **Mechanical Equipment:** The Power Connection to provide and install all conduit and conductors to, and fully connect the following HVAC/Mechanical equipment:
    - a. Reconnect fire pump to the new ATS required by the new NFPA code 120.
-

**Clarifications:**

- 1.** All material and equipment shall be new and shall bear the label of the Underwriters Laboratories, Inc., where such labels are available.
- 2.** Space for storage of materials on-site has been assumed for the purposes of this Proposal.
- 3.** Work is figured at normal rates.
- 4.** Generator pad is included.
- 5.** Core drilling is included in running conduit to new location of the generator.
- 6.** Start up and load banking is included.
- 7.** Proposed price contingent upon using a mutually agreed upon contract or purchase order.
- 8.** The Proposal is valid for 30 days from the date submitted.



REDEVELOPEMENT AUTHORITY

Switch SUBMITTAL

REVISION 1

Submittals provided for 232465 - GENHUB INC HARRISONBURG VA

John Wilson  
Sales Representative  
[jwilson@tpcgenerators.com](mailto:jwilson@tpcgenerators.com)

# REDEVELOPEMENT AUTHORITY

Reference Quote: E5-791869-01

Sales Order: N/A

TRANSFER SWITCH DETAILS									
ATS NAME	QTY	AMPS / POLES (VOLTS)	BYPASS	TRANSITION TYPE	CATALOG NUMBER	ACCESSORIES	OUTLINE DRAWING	WIRING DIAGRAM	BOM NUMBER
	1	0104 / 4 (240V)	N/A	OPEN	D03ATSB30104FGXC	11BE	-----	-----	TO BE ENGINEERED
	1	0400 / 4 (240V)	N/A	OPEN	J03ATSB30400FGXC	11BE	-----	-----	TO BE ENGINEERED

Transfer Switch Withstand and Closing Ratings																						
		300, 4000 & 7000 Series																				
ATS NAME	FRAME SIZE	SWITCH RATING AMPS		CURRENT LIMITING FUSES				SPECIFIC BREAKER			TIME BASED				Short Time Ratings <sup>3</sup> (sec)							
															480V Max.			600V Max.				
		Transfer Switches	Bypass Switches	480V Max.	600V Max.	MAX SIZE, A	CLASS	240V Max.	480V Max.	600V Max.	Time(Sec)	240V Max.	480V Max.	600V Max.	.13	.2	.3	.5	.1	.13	.3	.5
-	D	70, 100	-	35kA	35kA	200	RK1	150kA	85kA	25kA	0.025	10kA	10kA	10kA	-	-	-	-	-	-	-	
-	J	400	400	200kA	200kA	600	J	200kA	200kA	100kA	0.05	65kA	42kA <sup>5</sup>	35kA	7.5kA	-	-	-	-	-	-	-

**NOTES:**

- 1) All WCR values indicated are tested in accordance with the requirements of UL 1008, 7th Edition.
- 2) Application requirements may permit higher WCR for certain switch sizes.
- 3) Short Time ratings are provided for applications involving circuit breakers that utilize trip delay settings for system selective coordination

# REDEVELOPEMENT AUTHORITY

Transfer Switch Details

#1	ATS	AMPS: 0104	QTY: 1
Product : Series 300		Catalog Number : D03ATSB30104FGXC	
Service Voltage / Hz : 240V/60Hz		Optional Accessories : 11BE	
Bypass Isolation : Not Applicable		Product Description : 300 Series, Automatic Open Transition Transfer Switch	
No. of Switched Poles: : 4		Neutral Configuration : Switched [B]	
Withstand Rating: : See WCR Table Below  Frame = D, Switch Rating = 0104, Series = 300		No. of Cables & Lug Size : 1, #14 to 4/0 AWG	
Enclosure : 1(C)-UL Type 1 Enclosure		Service : Three Phase, 4-wire	
Extended Warranty : Not Included		Markings :	

	ACCESSORY DESCRIPTIONS	
#	Accessory Code	Description
No Accessories Included		

# REDEVELOPEMENT AUTHORITY

Transfer Switch Details

#2	ATS	AMPS: 0400	QTY: 1
Product	: Series 300	Catalog Number	: J03ATSB30400FGXC
Service Voltage / Hz	: 240V/60Hz	Optional Accessories	: 11BE
Bypass Isolation	: Not Applicable	Product Description	: 300 Series, Automatic Open Transition Transfer Switch
No. of Switched Poles:	: 4	Neutral Configuration	: Switched [B]
Withstand Rating:	: See WCR Table Below	No. of Cables & Lug Size	: 1, #4 AWG to 600 MCM or (2) 1/0 AWG to 250 MCM
Frame = J, Switch Rating = 0400, Series = 300			
Enclosure	: 1(C)-UL Type 1 Enclosure	Service	: Three Phase, 4-wire
Extended Warranty	: Not Included	Markings	:

#	ACCESSORY DESCRIPTIONS	
	Accessory Code	Description
No Accessories Included		



## EQUIPMENT STORAGE REQUIREMENTS

Equipment provided by Schneider-Electric and/or ASCO Power Technologies that is stored for a short-term duration (i.e., days to weeks) or long-term duration (i.e., months to years), must be kept in a cool, dry, temperature-controlled environment. Storage of equipment in open warehouses, locations without proper temperature and humidity control, and/or outdoor storage is not acceptable without the utilization of heating elements, thermostats, humidistats, and protection from weather and dirt. Failure to comply may result in moisture ingress and/or condensation to form resulting in rusting and or corrosion, component and/or equipment failure and replacement, and/or nullification of any manufacturer warranty.

For **General Instructions for Proper Handling, Installation, Operation, and Maintenance of Deadfront Distribution Switchboards Rated 600 Volts or Less**, refer to [ANSI NEMA PB 2.1-2013](#)

Copies of the following documents should be included on the submittals, depending on the units that are on the proposal:

For ASCO Power Technology's **Switchgear and Switchboards**, refer to Instruction Bulletin **381333-393**.

For Schneider-Electric/Square D's **Power Zone 4 (PZ4) Switchgear**, refer to Instruction Bulletin **80298-002-09**.

For Schneider-Electric/Square D's **Power Zone 4 (PZ4) NEMA 3R Walk-In Switchgear**, refer to Instruction Bulletin **80298-156-02**.

For Schneider-Electric/Square D's **Quality, Efficient, Delivery" (QED2) Switchboard**, refer to Instruction Bulletin **80043-055-14**.

For Schneider-Electric/Square D's **Masterclad Metal-Clad Indoor Switchgear**, refer to Instruction Bulletin **6055-30**.



# Flexible Power Transfer Solutions for Commercial & Industrial Applications

**ASCO** Power Technologies™

ASCO SERIES 300  
Power Transfer Switches



[se.com](http://se.com)

Life Is On

**Schneider**  
Electric

# ASCO SERIES 300 Automatic Transfer Switches

Power outages impact small and large facilities alike. ASCO SERIES 300 Automatic Transfer Switches offer rugged design and reliable performance to small and mid-size commercial and industrial facilities in packaged solutions that are easy to select, procure, install, and operate.

Every SERIES 300 generator transfer switch is engineered with ASCO's reliability expertise in a package that makes backup power accessible for small and mid-size facilities. Leveraging knowledge derived from a century of critical power transfer experience, each SERIES 300 is backed by the same ASCO technical support and service that solves the most demanding critical power challenges facing facilities today.

## Product Details

 [Transfer Switch  
Overview](#)



# SERIES 300 Automatic Transfer Switches

## Designed to Fit Anywhere

The ASCO SERIES 300 product line provides the most compact design of generator power transfer switches in the industry.

Available to mount on walls or floors, all models through 2000 amperes are designed to be completely front-accessible. This permits installation flush against walls while allowing installation of cabling and connections from the front of the switch. Cable entrance plates are standard on 1600 and 2000 amperes units; these allow use of optional side-mounted pull boxes for additional cable bending space.

- 30 through 3000 amperes in compact designs
- Up to 600 VAC, single or three phase
- Listed to UL 1008 - Standard for Safety - Transfer Switch Equipment
- True double-throw operation: The single solenoid design is inherently interlocked to prevent simultaneous connections of two power sources.
- Will not transfer to a dead source - single solenoid operator derives power from the destination source
- Easy-to-navigate 128x64 graphical LCD display with keypad provides LED indicators for switch position, source availability, not-in-auto mode, and alert conditions.
- Integrated, multilingual, user interface for configuration and monitoring
- Available Delayed Transition operation
- Optional Relay Expansion Module with extra relays for accessory outputs
- Soft keys for test function and time delay bypass
- Emergency source failure alert indication
- Optional Historical Event Log
- Displays statistical ATS monitoring information
- Built-in diagnostic functions
- Password protection to prevent unauthorized actions
- Adjustable delay feature prevents nuisance transfer due to momentary utility power outages and generator dips
- ASCO's patented Predictive Outage Detection feature senses voltage instability conditions or flickers and proactively starts the generator for protection of equipment and reduction of downtime
- Auxiliary contacts signal position of main contacts - two for normal and two for emergency position
- Standard solid neutral terminals
- Restriction of Hazardous Substances (RoHS) compliant controller
- Standard 2 year warranty. Optional 1, 2, and 3 year extensions

## Power Knowledge

 [Basic Automatic Transfer Switch Functions](#)



SERIES 300 Power Transfer Switch rated 200 amps

# SERIES 300 Automatic Switching Solutions

## Automatic and Non-Automatic Transfer Switching

ASCO Transfer Switches are available in both automatic and non-automatic types. Both are electrically operated. For automatic transfer switches, the controller initiates transfer between power sources. For non-automatic transfer switches, a user initiates transfer using local or remote controls.

SERIES 300 non-automatic transfer switches offer the following features:

- Models range from 30 through 3000 amperes, up to 600V
- Controller prevents inadvertent operation under low voltage conditions
- Source acceptability lights inform operator when sources are available to accept load
- Standard in-phase monitor for transferring motor loads between live sources

## Power Knowledge

 [Non-Automatic and Manual Transfer Switches for Backup Power Applications](#)



400 Amp, Type 1 Enclosure

## Open Transition Transfer Switching

ASCO Transfer Switches are available with a standard, 2-position, open transition models that reliably transfer loads in less than 50 milliseconds. Open transition switches are suitable for a wide range of applications.

- 30 to 3000 amps
- Single-operator switching mechanism prevents simultaneous connection of both sources
- Available In-Phase Monitor can be activated for transferring motor loads

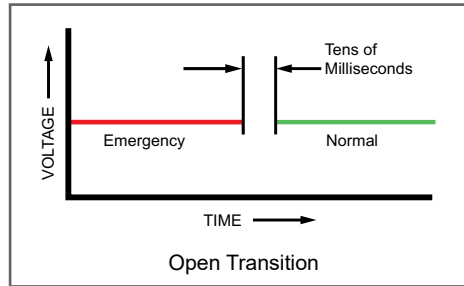

## Delayed Transition Transfer Switching

ASCO Delayed Transition Transfer Switches transfer loads between power sources using a timed load disconnect position with an adjustable delay.

- 150 through 3000 amps
- Reliable, field-proven, dual-solenoid operating mechanism
- Mechanical interlocks to prevent simultaneous connection of both power sources
- Adjustable delay for load disconnect - 0 to 5 minutes
- Non-automatic models available in manual operation configuration
- Automatic models available with load shed feature

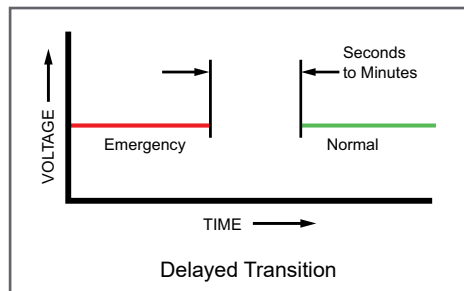

## Power Knowledge

[Transition Mode Basics](#)

[Transferring Motor Loads between Power Sources](#)

[Transferring Loads with Zero Power Interruption](#)

# SERIES 300 Group G Controller

The SERIES 300 Group G Controller is reliable and field-proven. It provides all of the voltage, frequency, control, timing, and diagnostic functions required for most emergency and standby power applications.

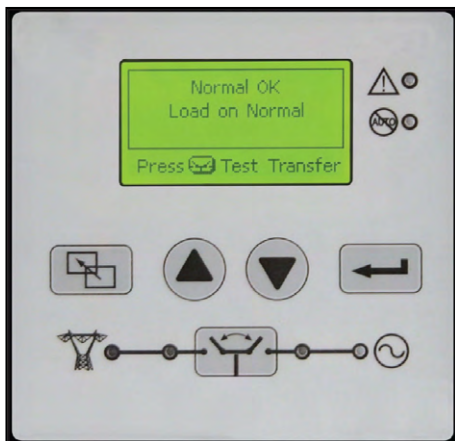

- Touch pad programming
- Displays active timers
- On-board diagnostics
- Password protection
- Voltage and frequency sensing
- Status and control functions
- Patented Predictive Outage Detection feature

## Product Details

[Group G Controller](#)

# Transfer Switch Communications and Metering

Options to Customize Functionality and Increase Value

## Product Details

 [5300 SERIES Annunciators](#)

### Remote Annunciation

#### Monitor Power Equipment Status from Anywhere

Monitoring and control transfer switches from across the room, building, or from Internet.

5310 – LED annunciator – Single ATS

5350 – LED annunciator – up to 8 ATSS



## Product Details

 [5140 Connectivity Module](#)

### Communication

#### Turn Transfer Switches into Power Information Portals

5140 Connectivity Module – Makes status and power information from a single switch available to via ModBUS, SNMP, and web pages.



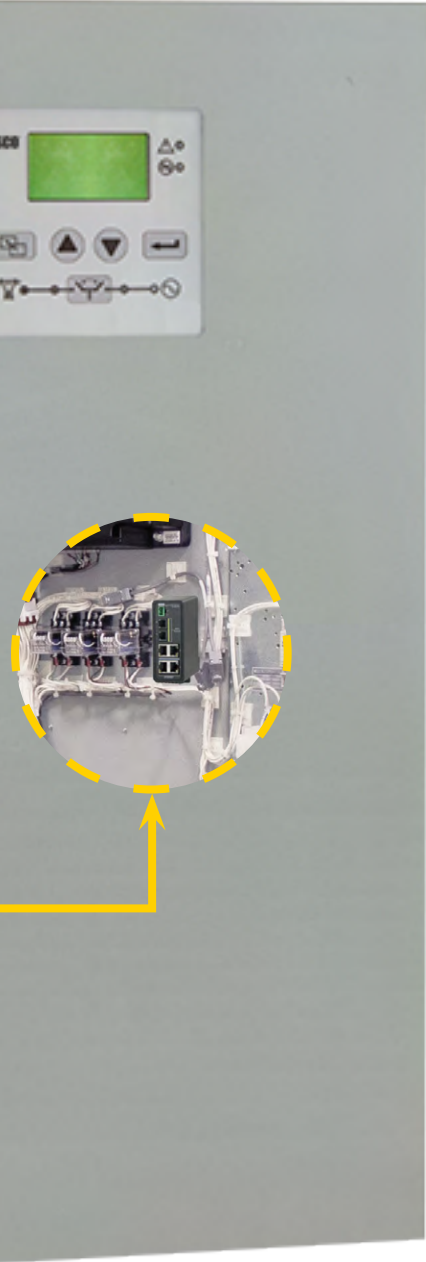

## Metering

### Transfer Switches are the Perfect Place to Monitor Power Flow, Power Conditions, and Power Events

5210 Power Meter – Provides deeper insight into circuit status and conditions.

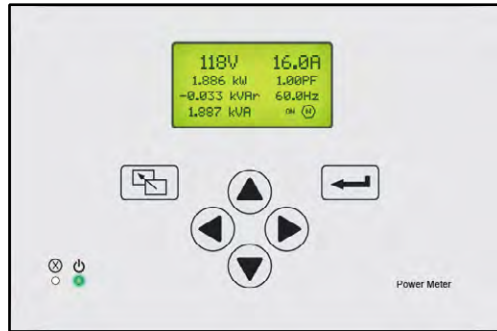

## Product Details

 [5210 Power Meter](#)

# SERIES 300 Optional Accessories

## Communications

<b>11BE</b>	Feature Bundle. Programmable engine exerciser with seven independent routines run the generator with or without loads, on a daily, weekly, bi-weekly, or monthly basis. Controlled from the user interface keypad. <ul style="list-style-type: none"> <li>Event log display shows the event number, time and date, type and reason (if applicable).</li> <li>Stores up to 300 events</li> <li>RS485 Communication Port enabled common alarm output contact</li> <li>On three-phase systems, Accessory 11BE enables line-to-line voltage imbalance sensing and three-phase sensing capabilities for the Emergency power source as well as the Phase Rotation checking for both power sources.</li> </ul>
<b>18RX</b>	Relay Expansion Module provides accessory relays and includes one Form C contact for normal source availability (18G), and one Form C contact for emergency source availability (18B) (contact rating 5 amperes @ 30 VDC or @ 125 VAC resistive) (100 ma, 4 VDC min) Additional output relay is provided the default is to indicate a common alarm.
<b>72EE</b>	Connectivity module provides remote monitoring and control capabilities and includes accessory 11BE feature bundle

## Environment and Power

<b>44A</b>	Strip heater with thermostat for cold environment to prevent internal condensation and icing. External 120-volt AC power source required.
<b>44G</b>	Strip heater with thermostat, wired to load terminals on 208-240, 360-380, 460-480, 550-600 volt models. Contains wiring harnesses for all transfer switch sizes.
<b>1UP</b>	UPS back up power runs controller and LCD display for 30 seconds without AC power

## Extension Harness

<b>37B</b>	Six-foot extension harness for open type units to accommodate customer mounting of controls and switch
<b>37C</b>	Nine-foot extension harness for open type units to accommodate customer mounting of controls and switch

## Indicators

<b>62W</b>	Audible alarm with silencing feature to signal transfers to emergency. (For D-frame models, may require oversize enclosure depending on accessory combination).
------------	---

## Customer Control Circuits

<b>30A</b>	Load-shed circuit initiated by opening of a customer-supplied contact (Open Transition model only)
<b>30B</b>	Load-shed circuit initiated by removal of customer-supplied control voltage (Open Transition model only)
<b>30AA</b>	Load-shed circuit initiated by opening of a customer-supplied contact (Delayed Transition model only)
<b>30BA</b>	Load-shed circuit initiated by removal of customer-supplied control voltage (Delayed Transition model only)

## Surge Protection

<b>73</b>	Surge suppressor rated 65 kA
-----------	------------------------------

## Metering

<b>23GA, 23GB</b>	Load Current Metering card measures either single or three-phase load current. Not available with Power Meter option 135L. Use 23GA for Single-Phase, 23GB for Three-Phase.
<b>135L</b>	Power Meter on load side (includes shorting block and current transformers). Not available with Load Current Metering options 23GA or 23GB.

## Field Conversion Kits

Kit No.	Description
935147	Advanced Function Bundle Retrofit Kit (11BE) - See above accessory 11BE description for details.
935148	REX Module with Source Availability Contacts (Acc. 18RX)
935149	UPS to allow controller to run for 30 seconds minimum without AC Power (Acc. 1UP)
935150	1/3 Phase load current sensing card only (Acc. 23GA/GB)
K613127-001	Strip Heater (125 watt) 120 volt (Acc. 44A)
K613127-002	Strip Heater (125 watt) 208-480 volt (Acc. 44G)
948551	Quad-Ethernet Module (Acc. 72EE)
K609027	Cable Pull Box (1600-2000 amperes)

# Withstand and Close-on Ratings

Withstand and Close-on Ratings for all 7000 SERIES Power Transfer Switches, including 0.5 second (30-cycle) designs.

Frame	Switch Rating (Amps)		Current Limiting Fuses				Specific Breaker			Time Based				Short Time Ratings <sup>3</sup> (sec)					
	Transfer Switches	Bypass Switches	480V Max.	600V Max.	Max Size, A	Class	240V Max.	480V Max.	600V Max.	Time (sec)	240V Max.	480V Max.	600V Max.	480V Max.			600V Max.		
														.13	.2	.3	.5	.1	.13
D	30	-	100kA	-	300	J	22kA	25kA	10kA	0.025	10kA	10kA	10kA	-			-		
			200kA	35kA	200	J								-			-		
			35kA	35kA	200	RK1								-			-		
D	70, 100	-	35kA	35kA	200	RK1	150kA	85kA	25kA	0.025	10kA	10kA	10kA	-			-		
			200kA	35kA	200	J								-			-		
			200kA	35kA	200	J								-			-		
D	150	-	35kA	35kA	200	RK1	150kA	85kA	25kA	0.025	10kA	10kA	10kA	-			-		
			200kA	35kA	200	J								-			-		
D	200	-	200kA	35kA	200	J	200kA	85kA	14kA	0.025	10kA	10kA	10kA	-			-		
			35kA	35kA	200	RK1								-			-		
D	230	-	100kA	-	300	J	200kA	85kA	14kA	0.025	10kA	10kA	-	-			-		
E	260, 400	-	200kA	-	600	J	65kA	42kA	22kA	0.05	35kA	35kA	22kA	-			-		
J	150, 200, 230, 260	150, 200, 230, 260	200kA	200kA	600	J	200kA	200kA	100kA	0.05	65kA	42kA <sup>5</sup>	35kA	7.5kA	-		-		
					800	L									-		-		
J	400	400	200kA	200kA	600	J	200kA	200kA	100kA	0.05	65kA	42kA <sup>5</sup>	35kA	7.5kA	-		-		
					800	L									-		-		
J	600	600	200kA	200kA	800	L	200kA	200kA	100kA	0.05	65kA	42kA <sup>5</sup>	35kA	7.5kA <sup>9</sup>	-		-		
H <sup>8</sup>	600	600	200kA	200kA	1600	L	65kA	150kA <sup>6</sup>	65kA	0.05	50kA	50kA	50kA	36kA	-		36kA	-	
P <sup>8</sup>	600	600	200kA	200kA	1600	L	65kA	150kA <sup>6</sup>	65kA	0.05	50kA	50kA	50kA	36kA	30kA	36kA	36kA	-	
P <sup>8</sup>	800	800 - 1200	200kA	200kA	1600	L	65kA	150kA <sup>6</sup>	65kA	0.05	50kA	50kA	50kA	36kA	30kA	36kA	36kA	-	
H	800 - 1200	800 - 1200	200kA	200kA	1600 <sup>4</sup>	L	65kA	150kA	65kA	0.05	50kA	50kA	50kA	36kA	-		36kA	-	
Q <sup>8</sup>	600-1600	600-1600	200kA	200kA	2000	L	65kA	65kA	65kA	0.05	65kA	65kA	65kA	50kA			50kA		
S <sup>8</sup>	800 - 1200	800 - 1200	200kA	200kA	2500	L	100kA	100kA	65kA	0.05	100kA	100kA	65kA	65kA			65kA		
G <sup>8</sup>	1000 - 1200	1000 - 1200	200kA	200kA	2000	L	85kA	85kA	85kA	0.05	85kA	85kA	85kA	-			-		
G	1600 - 2000 (Front Connected TS Only)	-	200kA	200kA	2500	L	85kA	85kA	85kA	0.05	85kA	85kA	85kA	42kA	36kA	-			
G <sup>8</sup>	1600 - 2000	1600 - 2000	200kA	200kA	3000	L	200kA	200kA	100kA	0.05	100kA	100kA	100kA	42kA	36kA	42kA	42kA	-	
S <sup>8</sup>	1600 - 2000	1600 - 2000	200kA	200kA	2500	L	100kA	100kA	85kA	0.05	100kA	100kA	85kA	85kA	65kA	85kA	85kA	65kA	
G	2600 - 3000	2600 - 3000	200kA	200kA	4000	L	125kA <sup>6</sup>	125kA <sup>6</sup>	100kA	0.05	100kA	100kA	100kA	42kA	36kA	42kA	42kA	-	
G <sup>8</sup>	3200	-	200kA	-	4000	L	100kA	100kA	-	0.05	100kA	100kA	-	-			-		
G	4000	4000	200kA	200kA	5000	L	100kA	100kA	100kA	0.05	100kA	100kA	100kA	85kA	65kA	65kA			
U <sup>8</sup>	2600 - 4000	2600 - 4000	200kA	200kA	5000	L	125kA	125kA	125kA	0.05	125kA	125kA	125kA	100kA			100kA		

**Notes:**

- All WCR values indicated are tested in accordance with the requirements of UL 1008, 7th Edition. See ASCO Pub. 1128 for more WCR information
- Application requirements may permit higher WCR for certain switch sizes.
- Short Time ratings are provided for applications involving circuit breakers that utilize trip delay settings for system selective coordination
- Max fuse rating is 1200A on front connected H frame switches
- Switches utilizing overlapping neutral (code "C") have 35kA, 0.050 Sec time based rating at 480V Max
- Rating shown is for Bypass switches only, Transfer Switch rating is 100kA for the G frame and 65kA max for the H and P frames. See ASCO Pub. 1128.
- See ASCO for Service Entrance Switch ratings
- These frames are only available on the 7000 Series product
- Short Time Rating applies to 600A Bypass switch only, the 600A Transfer Switch does not have a Short Time Rating

All units are RMS Symmetrical Amperes.

All Withstand and Close-on Rating (WCR) values are established by testing in accordance with UL 1008. For the latest ratings, including transfer switch ratings when used with specific circuit breakers, see **ASCO Publication 1128** for more WCR information.

Application characteristics may permit higher WCRs for certain switch sizes. Contact ASCO Power Technologies for more information.

## Power Knowledge

[UL 1008 Transfer Switch Withstand and Closing Ratings](#)

[Performance Testing for Transfer Switches](#)

## Additional SERIES 300 Product Information

Transfer Switches and Panels	Controls	Technical Information
<a href="#">Manual Transfer Switch</a>	<a href="#">Group G Controller</a>	<a href="#">Withstand and Closing Ratings</a>
<a href="#">Manual Transfer Switch with Quick Connects</a>		<a href="#">Weights and Dimensions and Ordering Info</a>
<a href="#">Quick Connect Power Panel</a>		<a href="#">Drawings</a>
<a href="#">Dual Purpose Quick Connect Power Panel</a>		<a href="#">Wiring Diagrams</a>

# SERIES 300 Manual Transfer Switching and Quick Connection Solutions

ASCO SERIES 300 Manual Transfer Switching and Quick Connection Solutions offer reliable service and application flexibility for a wide range of facilities.

## Manual Transfer Switches



- Three-position, easy-to-use center-off switch
- Compact design - easy to install and maintain
- Designed to handle demands of motors and inrush currents

## Power Knowledge

 [Differences Between Manual, Non-Automatic, & Automatic Transfer Switches](#)

## Product Details

 [SERIES 300 Manual Transfer Switch](#)

## Manual Transfer Switches with Quick Connects



- The ASCO SERIES 300 Manual Transfer Switch with Integrated Quick Connects provides a total temporary power connection and transfer solution
- Enables connection and control of a temporary or portable generator
- Provides a complete UL 1008-listed solution in a single unit

## Product Details

 [SERIES 300 Manual Transfer Switch with Quick Connects](#)

## Quick Connect Panels



- Listed to UL 1008 Transfer Switch Accessory standard
- Utilizes standard Cam-Lok™ receptacles for quick connections
- Standard Type 3R construction is weatherproof with or without cable
- Utilizes standard Series 16 Single Pole quick connect receptacles

## Power Knowledge

-  [NEC Requirement for Permanent Manual Switching Means](#)

## Product Details

-  [SERIES 300 Quick Connect Power Panel](#)

## Dual-Purpose Manual Transfer Switches with Quick Connects



- Provides both supplemental backup power and load testing connectivity through a single device.
- Listed by ETL to UL 891
- Utilizes standard Series 16 Single Pole quick connect receptacles

## Product Details

-  [SERIES 300 Dual Purpose Quick Connect Power Panel](#)

Life Is On



ASCO Power Technologies - Global Headquarters  
160 Park Avenue  
Florham Park, NJ 07932  
Tel: 800 800 ASCO

[www.se.com/us/en/brands/ascopower/  
customercare@ascopower.com](http://www.se.com/us/en/brands/ascopower/customercare@ascopower.com)

# Shipping, Handling, Moving and Storing of Transfer Switches and Power Control Systems

## Instructions

381333-512  
10/2024

---

## READ ME FIRST

---

Upon receipt, refer to the Handling instructions in this document and confirm that proper material handling equipment is available to move the products.

When the shipment arrives, inspect the shipping material for any signs of damage or mishandling. Do not attempt to install the system if damage is apparent. If any damage is noted, file a damage claim with the shipping carrier immediately.



**NOTE:** The above is an example of a typical Transfer Switch packaged on a skid.

## Legal Information

The Schneider Electric brand and any trademarks of Schneider Electric SE and its subsidiaries referred to in this guide are the property of Schneider Electric SE or its subsidiaries. All other brands may be trademarks of their respective owners.

This guide and its content are protected under applicable copyright laws and furnished for informational use only. No part of this guide may be reproduced or transmitted in any form or by any means (electronic, mechanical, photocopying, recording, or otherwise), for any purpose, without the prior written permission of Schneider Electric.

Schneider Electric does not grant any right or license for commercial use of the guide or its content, except for a non-exclusive and personal license to consult it on an “as is” basis. Schneider Electric products and equipment should be installed, operated, serviced, and maintained only by qualified personnel.

As standards, specifications, and designs change from time to time, information contained in this guide may be subject to change without notice.

To the extent permitted by applicable law, no responsibility or liability is assumed by Schneider Electric and its subsidiaries for any errors or omissions in the informational content of this material or consequences arising out of or resulting from the use of the information contained herein.

## Table of Contents

Safety Precautions.....	5
Introduction .....	6
Packaging.....	6
Receiving and Handling .....	6
Receiving.....	6
Handling in Transit/Handling with a Forklift.....	6
Storing .....	9
Moisture Contamination Avoidance and Mitigation .....	9
Shipping and Storing Requirements.....	10
Exposure to Moisture, Chemicals and Condensation .....	10
Site Moving and Handling Guidelines.....	11
Moving .....	11
Handling with Lifting Eyes .....	12
Handling with Lifting Plates (NEMA 3R).....	13
Handling without Lifting Eyes or Plates .....	14
Material Handling Types .....	15

## Safety Information

### Important information

Read these instructions carefully and look at the equipment to become familiar with the device before trying to transport, move or install it. The following special messages may appear throughout this manual or on the equipment to warn of potential hazards or to call attention to information that clarifies or simplifies a procedure.



The addition of either symbol to a “Danger” or “Warning” safety label indicates that an electrical hazard exists which will result in personal injury if the instructions are not followed.

This is the safety alert symbol. It is used to alert you to potential personal injury hazards. Obey all safety messages that accompany this symbol to avoid possible injury or death.

### **⚠ DANGER**

**DANGER** indicates a hazardous situation which, if not avoided, **will result in** death or serious injury

### **⚠ WARNING**

**WARNING** indicates a hazardous situation which, if not avoided, **could result in** death or serious injury

### **⚠ CAUTION**

**CAUTION** indicates a hazardous situation which, if not avoided, **could result in** minor or moderate injury

### **NOTICE**

**NOTICE** is used to address practice not related to physical injury. The safety alert symbol shall not be used with the signal word

### Please note

Electrical equipment should be transported, moved and installed only by qualified personnel. No responsibility is assumed by ASCO POWER TECHNOLOGIES for any consequences arising out of the use of this material.

A qualified person is one who has skills and knowledge related to the construction, installation, handling and operation of the electrical equipment and has received safety training to recognize and avoid the hazards involved.

# Safety Precautions

<b>⚠ WARNING</b>
<p><b>HAZARD OF ELECTRIC SHOCK, EXPLOSION, OR ARC FLASH</b></p> <ul style="list-style-type: none"> <li>• Do not unpack the equipment before the time of installation.</li> <li>• Cover the units and store the units in a temperature controlled indoor environment free of conductive contaminants and humidity, where the units are protected from moisture until the time of start-up. Moisture inside the cabinet can create hazardous short circuits.</li> <li>• Contact your local ASCO Power Technologies representative if you have any questions concerning the equipment.</li> </ul> <p><b>Failure to follow these instructions can result in death, serious injury, or equipment damage.</b></p>

Improper handling/storage, water or other foreign material ingress may create electric shock hazards.

Refer to the outline and wiring drawings provided with the ASCO Power Technologies equipment for all installation and connection details and accessories.

<b>⚠ WARNING</b>
<p><b>TIPPING HAZARD UNBALANCED LOAD</b></p> <ul style="list-style-type: none"> <li>• Lift and move carefully and only with appropriate lifting equipment and trained personnel.</li> <li>• This cabinet may tip over when not fixed in place.</li> <li>• Ensure cabinet is secure prior to removing anchoring.</li> </ul> <p><b>Failure to follow these instructions can result in death, serious injury, or equipment damage.</b></p>
<b>⚠ ADVERTENCIA</b>
<p><b>PELIGRO DE VUELCO POR CARGA DESBALANCEADA</b></p> <ul style="list-style-type: none"> <li>• Levante y mueva con cuidado, y solo con el equipo de elevación adecuado y con personal capacitado.</li> <li>• Este gabinete puede volcarse si no está fijado.</li> <li>• Asegúrese de que el gabinete esté bien sujeto antes de quitar los anclajes.</li> </ul> <p><b>El incumplimiento de estas instrucciones puede causar la muerte, lesiones graves o daño al equipo.</b></p>
<b>⚠ AVERTISSEMENT</b>
<p><b>DANGER DE BASCULEMENT – CHARGE DÉSÉQUILIBRÉE</b></p> <ul style="list-style-type: none"> <li>• Soulever et déplacer avec précaution, uniquement par du personnel formé et à l'aide d'un équipement de levage approprié.</li> <li>• Cette armoire peut basculer si elle n'est pas fixée en place.</li> <li>• Assurez-vous que l'armoire est bien fixée avant de retirer l'ancrage.</li> </ul> <p><b>Si ces directives ne sont pas respectées, cela peut entraîner la mort, des blessures graves ou des dommages matériels.</b></p>

1513625-004 (-)

**NOTE: The above label should not be removed and should remain on the product throughout its lifecycle.**

## Introduction

This manual is provided as a supplement to address the Shipping, Handling, Moving and Storage of the ASCO Power Technologies equipment prior and up to installation. Any discrepancies between this manual and product manual for the equipment, the product manual overrides this Shipping, Handling, Moving and Storing supplement. The product manual and other documents are located inside the equipment and are to be used by the installer then remain with the equipment for the owner/operators use.

## Packaging

The equipment is assembled, wired, adjusted, and completely tested at the factory. It is then inspected and packed for shipment at the assembly plant. Most equipment is shipped fully assembled; in some cases, the switch may be shipped in sections for easier handling. When the equipment is shipped in sections the outline drawing will provide details on the shipping splits. The equipment or an equipment section is bolted on a wooden shipping skid and wrapped for shipment. All internal instruments, relays and components are properly blocked to prevent damage to bearings and movements if required. All sections are marked with the factory sales order number and weight. An envelope on the external wrapping contains the bill of lading which identifies the products shipped and provides the weight of the total shipment (weight of all units added together).

## Receiving and Handling

### Receiving

Upon receipt, check the packing list against the equipment received to ensure the order and shipment are complete. Also, upon receipt, immediately inspect transfer switch for any damage that occurred in transit. If damage is found or suspected, file a claim with the carrier immediately.

### Handling in Transit / Handling with a Forklift

#### **⚠ WARNING**

##### **SPECIAL HANDLING REQUIREMENTS**

- Do not lay the equipment on its front or sides.
- Lay equipment on its back only when special handling is required per Site and Moving and Handling Guidelines on page 11.
- Do not ship the equipment in a lying down position.
- Identify Center of Gravity label(s) to avoid creating an unbalanced load.

**Failure to follow these instructions can result in serious injury or equipment damage.**

Ensure that proper material handling equipment is available at the installation site to handle the ASCO Power Technologies equipment. The proper material handling equipment helps avoid injury to personnel and damage to the ASCO Power Technologies equipment.

The shipping weight of each shipping section is marked on the product. Verify the lifting capacity of the equipment being used to handle the ASCO Power Technologies equipment. in accordance with the shipping weight of each shipping section. Refer to page 11 Site Moving and Handling Guidelines.

The center of gravity (CoG) label is marked on the equipment. (Figure 1).



Figure 1. Center of Gravity label.



Before moving the ASCO Power Technologies equipment with a forklift, other powered or manual pallet lift:

- Read warning and fork access labels on the equipment (Figure 2).
- Lift from side(s) indicated on packaging.
- Check the fork lengths to ensure the forks extend under the entire skid.
- Set the forks to their widest point that will fit under the skid.
- Use a strap when handling or moving the equipment with a forklift.
- Carefully balance the load.
  - Center the forks on the equipment or if the equipment is marked with the center of gravity (Figure 1), center the forks based on the marking.
  - Ensure strap is around the equipment. (Recommended 36"-60" from the skid.)
  - Raise the forks slowly.
  - If the equipment is not balanced on the forks, stop, lower the forks, and reposition.

When moving equipment in a trailer:

- Set switchgear and/or switchboard along the side of the trailer.
- Strap to trailer wall at or above the midpoint of the equipment (typically between 48" and 60") and/or use airbags or dunnage between equipment and between equipment and the trailer wall.

The center of gravity label should only be removed once the product is secured in its final position.

Figure 2. Warning labels on the equipment.

These labels should remain in place until the product is secured in its final position. After the product is secured, the labels can be removed. These shipping labels and the center of gravity label use a non-permanent adhesive.

**⚠ WARNING**  
**TIPPING HAZARD UNBALANCED, HEAVY LOAD**  
 • Ensure proper support under heavy end before moving equipment.  
 • Secure to forklift with safety strap.  
 • Ensure forklift capacity suitable for load.  
 Failure to follow these instructions can result in death, serious injury or equipment damage.

**⚠ ADVERTENCIA**  
**PELIGRO DE VUELCO CARGA DESBALANCEADA, CARGA PESADA**  
 • Asegure un soporte adecuado debajo del extremo pesado antes de mover el equipo.  
 • Asegúrelo al montacargas con una correa de seguridad.  
 • Asegúrese de que la capacidad del montacargas sea adecuada para la carga.  
 El incumplimiento de estas instrucciones puede provocar la muerte, lesiones graves o daños al equipo.

**⚠ AVERTISSEMENT**  
**RISQUE DE BASCULEMENT CHARGE NON ÉQUILIBRÉE**  
 • Assurez-vous d'un support adéquat sous l'extrémité lourde avant de déplacer l'équipement.  
 • Fixez au chariot élévateur avec une sangle de sécurité.  
 • Assurez-vous que la capacité du chariot élévateur est adaptée à la charge.  
 Le non-respect de ces instructions peut entraîner la mort, des blessures graves ou des dommages matériels.

Remove label after installation  
 Retire la etiqueta después de la instalación  
 Enlever l'étiquette après l'installation

**Special Handling Requirements**  
 Do not lay the equipment on it's front or sides. Do so will damage unit.  
 Equipment may only be laid on it's back for manipulating into place, per ASCO Moving Guidelines for Transfer Switches.  
 Equipment is NOT to be shipped laying down unless prepared by ASCO.  
 Failure to follow these instructions can result in death, serious injury or equipment damage.

**Requisitos especiales de manejo**  
 No coloque el equipo de frente o de lado. Si lo hace, dañará la unidad.  
 Coloque el equipo boca arriba solo cuando se requiera manejarlo para ponerlo en su posición, conforme a las directrices de ASCO para mover los tableros.  
 NO debe enviarse el equipo acostado a no ser que lo haya preparado ASCO.  
 El incumplimiento de estas instrucciones puede provocar la muerte, lesiones graves o daños al equipo.

**Exigences spéciales de manutention**  
 Ne posez pas l'équipement sur le devant ou sur les côtés. Cela endommagerait l'unité.  
 Couchez l'équipement uniquement sur le dos lorsqu'une manipulation spéciale est nécessaire.  
 L'équipement ne peut être posé que sur le dos pour être manipulé en place, conformément aux instructions de l'ASCO.  
 L'équipement ne doit PAS être expédié couché à moins d'avoir été préparé par ASCO.  
 Le non-respect de ces instructions peut entraîner la mort, des blessures graves ou des dommages matériels.

1513625-001 (-)

**⚠ WARNING**  
**TIPPING HAZARD UNBALANCED, HEAVY LOAD**  
 • No lifting this side.  
 Failure to follow these instructions can result in death, serious injury or equipment damage.

**⚠ ADVERTENCIA**  
**PELIGRO DE VUELCO CARGA DESBALANCEADA, CARGA PESADA**  
 • No lo levante por este lado.  
 El incumplimiento de estas instrucciones puede causar la muerte, lesiones serias o daño al equipo.

**⚠ AVERTISSEMENT**  
**RISQUE DE RENVERSEMENT, CHARGE DÉSEQUILBRÉE**  
 • Pas de levage de ce côté.  
 Si ces directives ne sont pas respectées, cela peut entraîner la mort ou des blessures graves ou des dommages matériels.

Remove label after installation  
 Retire la etiqueta después de la instalación  
 Enlever l'étiquette après l'installation

1513625-002 (-)

**⚠ WARNING**  
**TIPPING HAZARD UNBALANCED, HEAVY LOAD**  
 • Ensure proper support under heavy end before moving equipment.  
 • Secure to forklift with safety strap.  
 Failure to follow these instructions can result in death, serious injury or equipment damage.

**⚠ ADVERTENCIA**  
**PELIGRO DE VUELCO DESEQUILIBRIO, CARGA PESADA**  
 • Asegure un soporte adecuado debajo del extremo pesado antes de mover el equipo.  
 • Asegúrelo al montacargas con una correa de seguridad.  
 El incumplimiento de estas instrucciones puede provocar la muerte, lesiones graves o daños al equipo.

**⚠ AVERTISSEMENT**  
**RISQUE DE BASCULEMENT DÉSEQUILIBRÉ, CHARGE LOURDE**  
 • Assurez-vous d'un support adéquat sous l'extrémité lourde avant de déplacer l'équipement.  
 • Fixez au chariot élévateur avec une sangle de sécurité.  
 Le non-respect de ces instructions peut entraîner la mort, des blessures graves ou des dommages matériels.

Shipping weight:

Remove label after installation  
 Retire la etiqueta después de la instalación  
 Enlever l'étiquette après l'installation

**FORK ACCESS**  
**ACCESO DE LAS HORQUILLAS**  
**ACCÈS DES FOURCHES**

1513625-003 (-)

# Storing

## Moisture Contamination Avoidance and Mitigation

### **⚠ DANGER**

#### **HAZARD OF ELECTRIC SHOCK, EXPLOSION, OR ARC FLASH**

- Store the equipment in a clean, dry (including no condensation), well-ventilated area with an ambient temperature of approximately 70 °F (21 °C).
- If heaters that are powered from an external source are furnished in the assembly, energize them from an external source.
- If heaters are installed that are powered from the equipment load, provide external heaters per the instructions in this manual.
- If heaters that are powered from an external source are not installed in the assembly, and there is risk of condensing humidity, use a temporary heating source within the assembly. A minimum of 250 watts of heat per section is recommended.
- Avoid greasy, smoky heaters that can deposit carbon on insulation, which could lead to tracking and insulation breakdown.
- If moisture, condensation, or chemical ingress is observed, do not energize the equipment. If the equipment is already energized, de-energize it immediately.

**Failure to follow these instructions can result in death or serious injury.**

### **⚠ WARNING**

#### **FIRE HAZARD**

Remove all flammable material in the vicinity of the heaters, such as packaging, accessories in boxes, and documentation, before energizing the heaters.

**Failure to follow these instructions can result in death, serious injury or equipment damage.**

## Shipping and Storing Requirements

Equipment Enclosures do not achieve their ratings until installed per the manual and outline drawings. Prior to installation, this equipment must be stored in a climate-controlled area that uses both heating and cooling to maintain an acceptable environmental conditions. Outdoor rated equipment is not suitable for outdoor storage unless heaters are installed and operational and the equipment is made watertight in accordance with any requirements in the switch manual.

- The equipment should be treated as if it is in storage until it is installed and operational or installed with the heaters operational.
- Equipment should not be stored outdoors. If they must be stored outdoors, they should be covered, and temporary electrical heating should be installed to prevent condensation.
- The storage area should be clear of any construction dust/dirt/debris.
- The storage area should be clean, dry, having uniform temperature to prevent condensation. The storage area must be climate controlled with proper ventilation.
  - Humidity limits: non-condensing relative humidity.
  - Temperature limits (ATS) -22 to 176 °F (-30 to 80 °C).  
(PCS) 0 to 140 °F (-17 to 60 °C)
- If heaters that were not supplied by the manufacturer, they must be clean and free of debris and grease. Greasy and/or smoky heaters can contaminate electrical insulation and lead to dielectric breakdown and/or tracking. Heaters should be at least 250 watts.
- Shipping packaging is not suitable for and cannot be used by itself for equipment storage.
- When receiving equipment, the equipment may be at a lower temperature than the ambient air temperature. Allow time for the equipment temperature, including the temperature of internal components, to rise to the ambient air temperature before making openings in or otherwise disturbing the packaging. Condensation can occur on and inside the equipment if warm air contacts cold surfaces of the equipment. Moisture damage can occur, destroying the dielectric capabilities of the equipment and rendering it unusable.
- The factory shipping wrap around the equipment on shipping pallets is not suitable for non-enclosed over-the-road transportation that risks exposing the equipment to the elements. The factory shipping wrap around the equipment should remain on the equipment until the equipment is ready to be inspected and stored or inspected and installed. After receiving the equipment and allowing it to acclimate to the environment, remove the packaging and inspect the equipment for damage that may have occurred in transit. If damage is found or suspected, immediately file a claim with the carrier and notify your Schneider Electric representative.
- Follow these guidelines every time the equipment is moved to a new storage location or to its final destination.

## Exposure to Moisture, Chemicals, and Condensation

If liquids such as moisture, chemicals, and condensation contact the electronics, circuit breakers, fuses, bussing, or other electrical components, do not attempt to clean or repair the equipment as this may lead to unrepairable damage. If the equipment is energized, de-energize it. If equipment is not energized, do not energize it. Contact-ASCO POWER SERVICES, Inc at 1-800-800-2726 (ASCO).

# Site Moving and Handling Guidelines

## Moving

Care must be exercised in moving and transporting equipment. Permanent damage to the connectors, guides, and frame can occur if improperly moved, voiding the ASCO warranty. A professional rigging company should be employed to move or transport equipment.

All ASCO Power Technologies equipment shall be in the upright position when transported via truck, train, boat, or airplane unless packaged on their back by ASCO Power Technologies at the factory. Equipment cannot be transported in any orientation other than vertical or on their back if packaged by ASCO Power Technologies. It is not recommended to package Power Control Systems on their back. If this is required, contact the ASCO Power Technologies Project manager at 1-800-800-2726 (ASCO).

Tables 1, 2 and 3 provide guidelines on moving ASCO Power Technologies equipment once they reach their destination. The tables are applicable to UL Type 1/3R/4/12 enclosures and open configurations only; all other enclosures must be moved in the upright position.

**Table 1. ASCO 300/7000 SERIES (non-Bypass)**

Switch Rating (amps)	Tilted or Laid on Back		
	Open Configuration	Enclosed UL Type 1	Type 3R/4/12 Enclosure
D 20 through 230	Yes	Yes	Yes**
J 150 through 600			
H 600 through 1200			
G 1600 through 3000			No
G 4000*	No	No	No

\* 7000 SERIES only

\*\* Welded Enclosures only

**Table 2. ASCO 7000 SERIES (Bypass)**

Switch Rating (amps)	Tilted or Laid on Back		
	Open Configuration	Enclosed UL Type 1	Type 3R/4/12 Enclosure
J 150 through 600	No	No	No
H 600 through 1200	Yes	Yes	
G 1600 through 3000			
G 4000	No	No	

**Table 3. ASCO 185 SERIES**

Switch Rating (amps)	Tilted or Laid on Back		
	Open Configuration	Enclosed UL Type 1	Type 3R/4/12 Enclosure
D 20 through 230	Yes	Yes	Yes
E 260 through 400			

See Material Handling Types for lifting specific enclosures (page 15).

## Handling with Lifting Eyes

Welded NEMA Type 3R/12/4 enclosures may be provided with lifting eyes. When using the lifting eyes with an overhead crane, and cables or chains use a rigid spreader bar. See Figure 3.

Figure 3. Lifting with Eye Bolts.

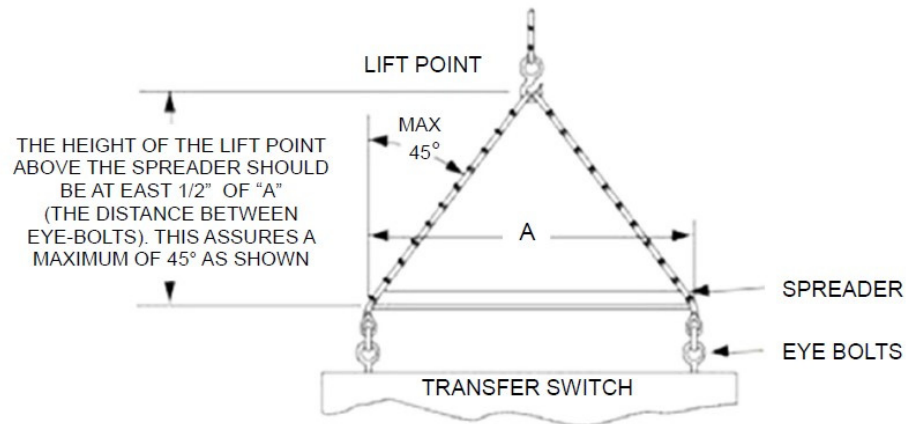

Follow these instructions to handle the equipment:

1. Use load-rated cables or chains with safety hooks or shackles. Do not pass cables or chains through lifting eyes.
2. Use load-rated spread bar to prevent structural damage. Rig so that the minimum angle between the lifting cables or chains and equipment top is 45 degrees.

Follow these instructions for laying equipment on it back:

1. Secure to overhead crane with load-rated cables or chains with safety hooks or shackles.
2. Raise the crane to remove any slack.
3. Remove from shipping skid.
4. Rate of lowering or pickup for laying equipment on its back is four feet per minute or less.
5. Move crane and provide blocking to prevent equipment from sliding.
6. Reverse the procedure to stand the equipment in its upright position.

## Handling with Lifting Plates (NEMA 3R)

NEMA Type 3R enclosures may be provided with lifting plates. When using the lifting plates with an overhead crane, and cables or chains use a rigid spreader bar. See Figure 4.

Figure 4. With Lifting Plates.



## Handling without Lifting Eyes or Plates

Equipment without lifting eyes require rollers, slings, or other means to handle and should be moved by an experienced Rigger in accordance with ANSI/NEMA PB 2.1 and the instructions below. When slinging use two sets of slings with spreader bars. See Figure 5.

Figure 5. Handling without Lifting Eyes.

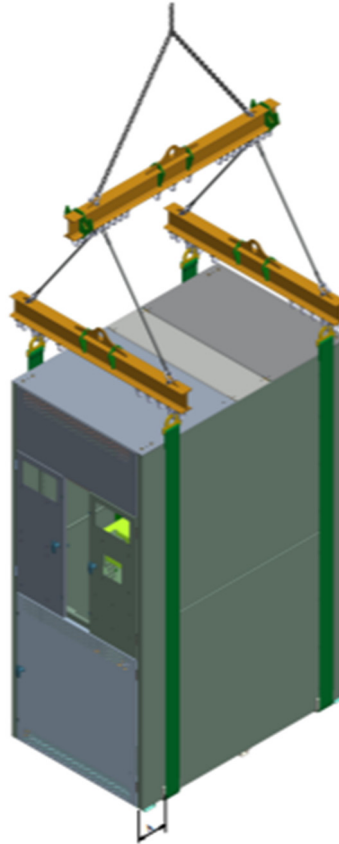

# Material Handling Types

## Type 1 Enclosures – Skid

Cubicle Deep, Skid

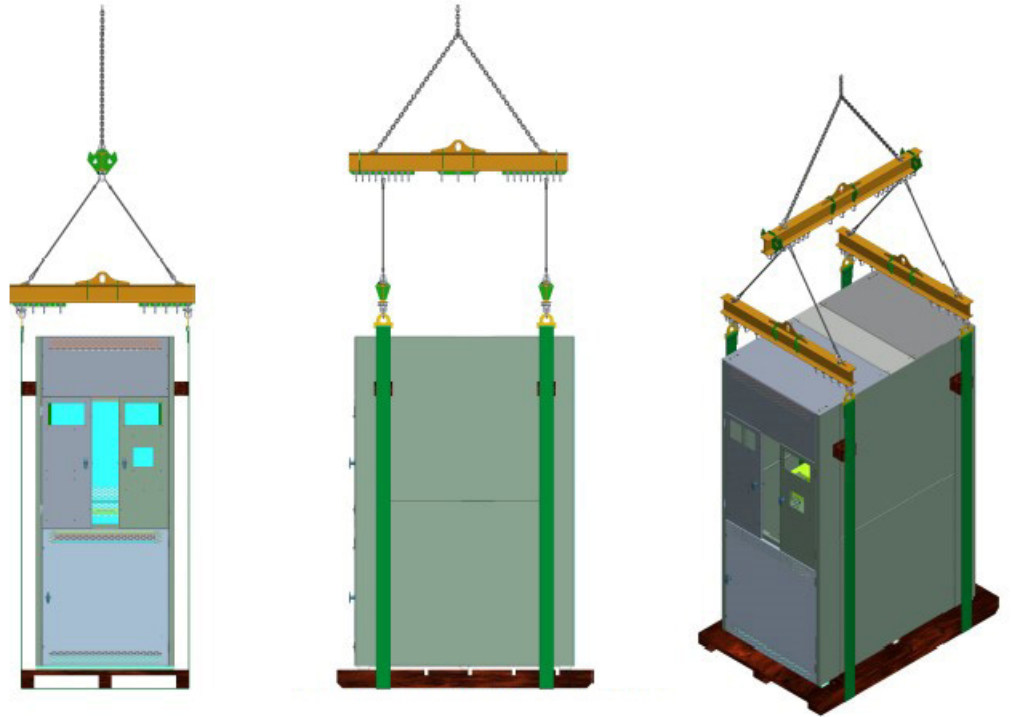

Cubicle Shallow, Skid

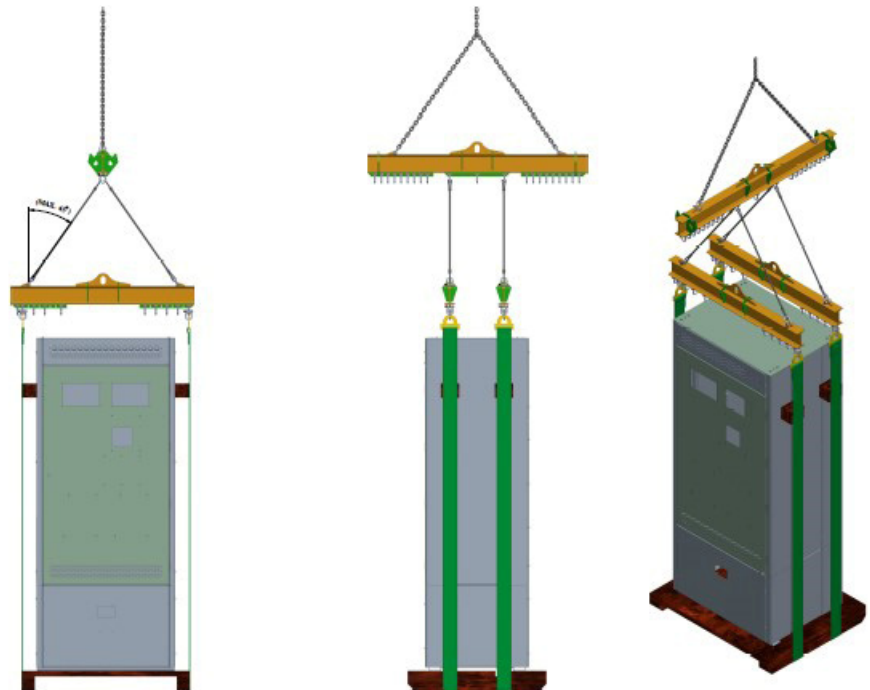

# Type 1 Enclosures – Sling

## Cubicle Deep, Sling

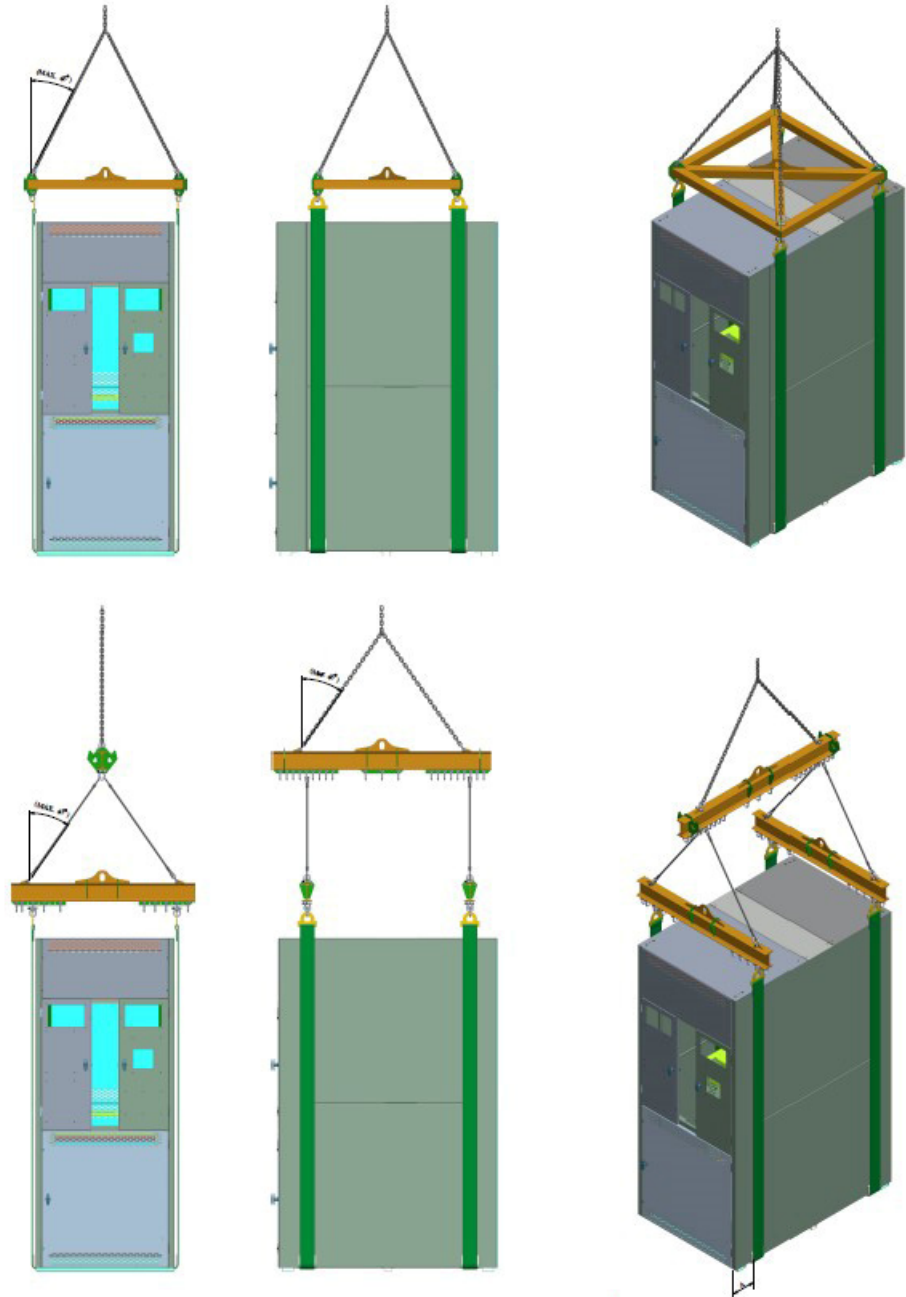

## Type 3R Enclosures – with Lifting Eyes

### Cubicle with 2 Lifting Eyes

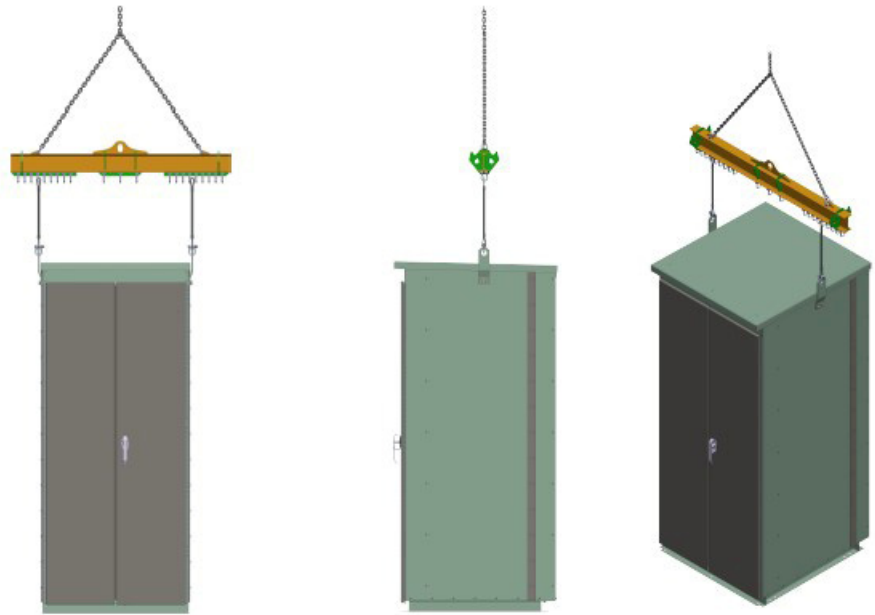

### Cubicle with 4 Lifting Eyes

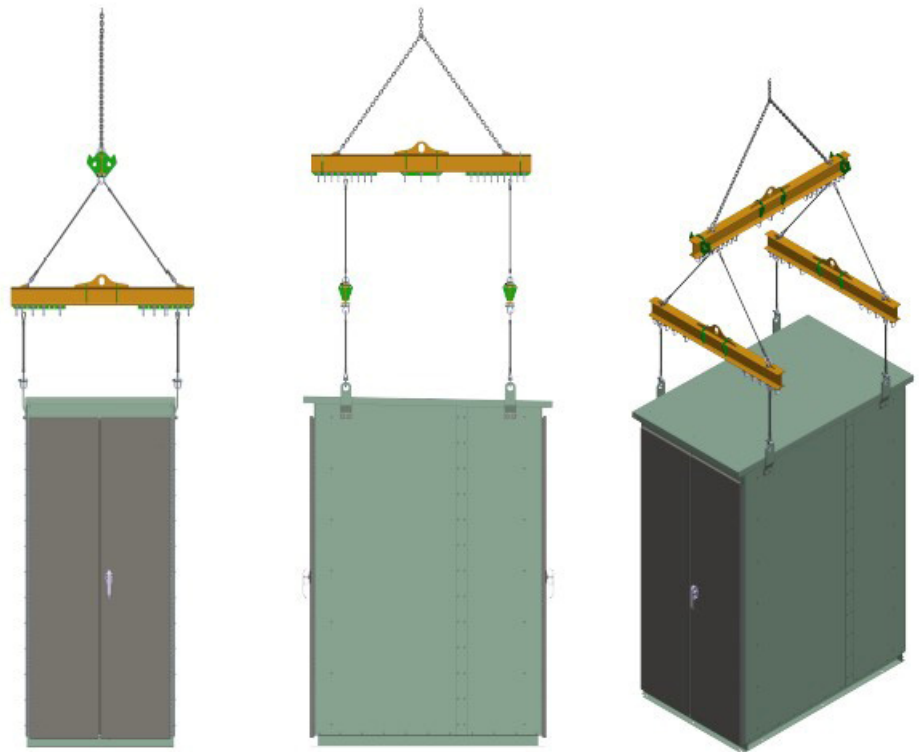

## Type 4 Welded Enclosures – with Lifting Eyes

### Welded Enclosures with 4 Lifting Eyes

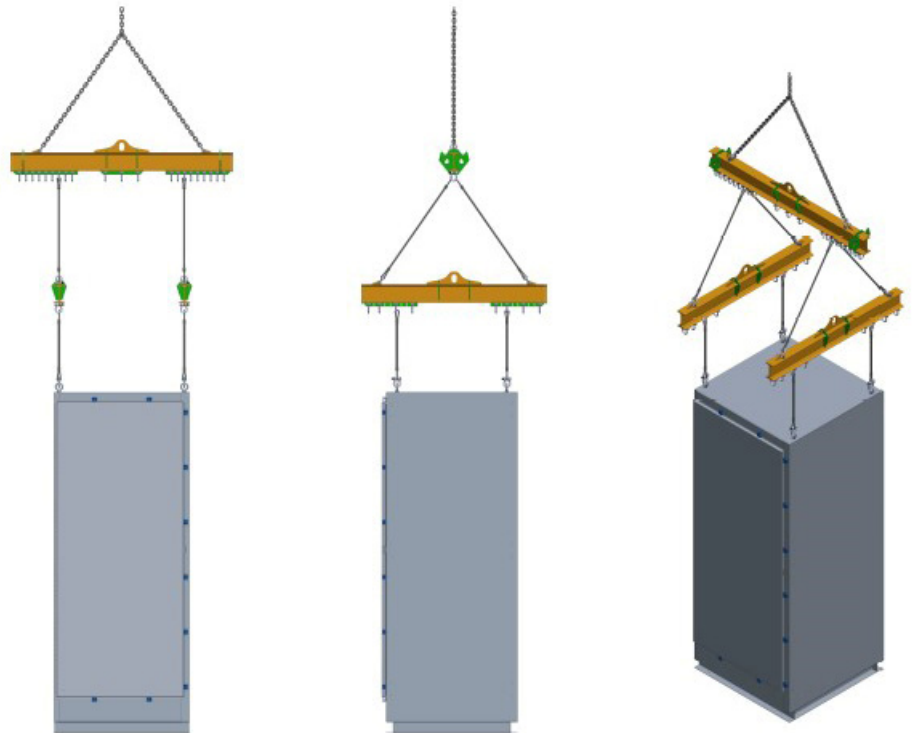
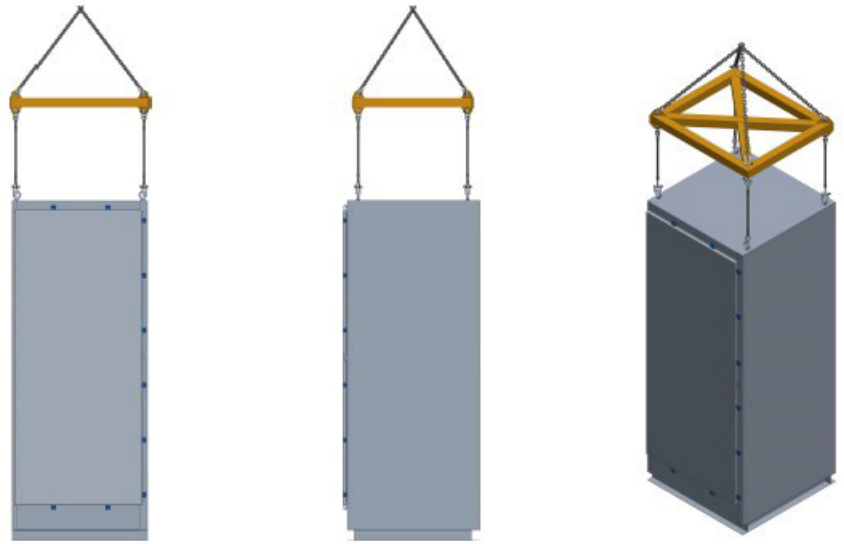

# Type 12 Welded Enclosure – with Lifting Eyes

## Welded Enclosures with 2 Lifting Eyes

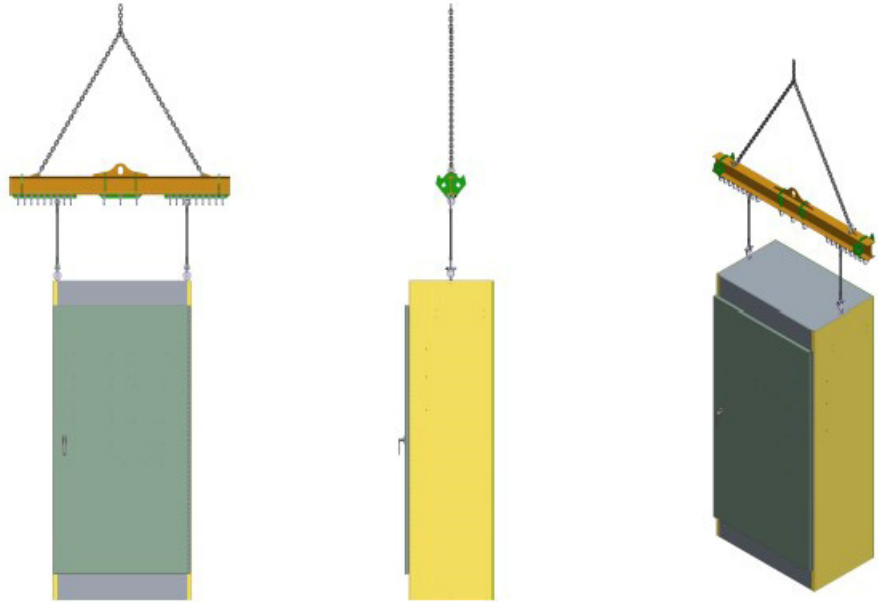

ASCO Power Technologies  
160 Park Avenue  
Florham Park, NJ 07932-1591 USA  
Phone: 1 800 800-2726 (ASCO) for sales or service  
[www.ascopower.com](http://www.ascopower.com)

©2024 ASCO Power Technologies. All Rights Reserved

MODEL

## HDI-100F

60Hz | STANDBY POWER



100kW | 1800RPM

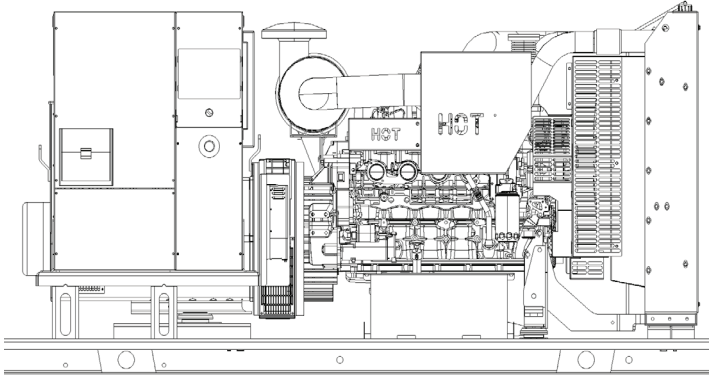

VOLTAGE VAC	120/240V	120/208V	139/240V	277/480V	347/600V
RATING	Standby	Standby	Standby	Standby	Standby
PHASE	1	3	3	3	3
PF	1.0	0.8	0.8	0.8	0.8
HZ	60	60	60	60	60
KW	100	100	100	100	100
KVA	100	125	125	125	125
AMPS	417	347	301	150	120

### DESCRIPTION

HIPOWER® Heavy Duty Industrial generators are an efficient, reliable and versatile source of back-up electrical power that have been designed to operate in the most extreme working conditions. All HIPOWER® Heavy Duty Industrial generators combine an innovative design and the use of high quality materials that provide the user with the most dependable power that can be relied on for non-stop power with easy to operate controls.

Powered by a radiator-cooled, industrial FPT Diesel engine that meets current Environmental Protection Agency (EPA) TIER 3 exhaust emission regulations, driving a single bearing, four-pole, three-phase alternator, with IP23 protection. The Emergency Power kVA rating is given with a 125 degree °C alternator winding temperature rise.

### HIPOWER® FEATURES AND BENEFITS

**FPT ENGINE:** Diesel Engine: Long-life, heavy-duty, 4-cycle, direct injection engine for economy of operation and maximum reliability and durability.

**Cooling:** Radiator with belt driven pusher fan.

**Air Filter:** Heavy-duty replaceable element air-cleaner.

**Alternator:** Single bearing, rotating field, self-excited, self-ventilated, 12-wire reconnectable, 60Hz brushless alternator and Class H insulation. Automatic voltage regulator (AVR) providing close voltage regulation and skVA starting capability for electric motor loads.

**Enclosure:** Fully sound attenuated enclosure, manufactured using 7-gauge steel and thicker for the base; 12-gauge and 14-gauge for the enclosure, Interpon A4700 primer, in combination with Interpon 600 series coatings, are designed for exterior exposure and offers excellent light and weather resistance exceeding 1400-hr salt spray test. A 1" thick layer of durable sound insulating, oil and fire resistant foam material is installed all around the inside of the enclosure to allow high-pressure water cleaning. Vertical air discharge for quiet operation. Wide steel lockable access doors with rubber seals, easy access for maintenance and service activities, lift off Die Cast Zinc hinges textured black powder coat and corrosion resistant hardware and fasteners.

**Exhaust:** Low noise, steel residential-type exhaust silencer with rain cap.

**Fuel Filtration:** Standard and secondary water separator with visible level on fuel filters.

**Controls:** Digital control panel with manual and automatic start and stop features. Many programmable automatic functions for local and remote controls with LED lights and tamper proof engine hour recorder.

**Certification:** Our Generators are ANSI/CAN/UL/ULC STD 2200:220Ed.3+R05Sep2025 certified and meets ISO 8528-5.

HIMOINSA POWER SYSTEMS, INC.

16600 S. Theden Street, Olathe, KS 66062

Toll Free: 866-710-2988 | [HIPOWERSYSTEMS.COM](http://HIPOWERSYSTEMS.COM)

Codes and Standards Compliances used where applicable



## APPLICATION DATA

ENGINE SPECIFICATION		LUBRICATION SYSTEM	
Manufacturer	FPT - Iveco	Oil pan capacity - gal (L)	3.2 (12)
Model	N67TM1X	Oil pan capacity with filter - gal (L)	4.5 (17.2)
EPA Certified	Tier 3	Oil cooler	Liquid
Crankshaft Speed	1,800 rpm	Recommended lubricating oil grade	SAE 10W-30 / ACEA E3/E5 (refer to owners manual)
Type	Diesel, 4-stroke	Oil consumption at full load	< 0.1% of fuel consumption
Injection	Direct	Oil pressure – psi (kPa)	72.6 (500)
Aspiration	Turbocharged aftercooled air/air	ENGINE ELECTRICAL SYSTEM	
Number of Cylinders	6	Starting motor voltage	12 volt
Cylinder Arrangement	In-line	Cold Cranking Amps - minimum	650 Amp
Displacement CID (liters)	408.9 (6.7)	Battery charging Alternator	90 Amp
Bore & Stroke Ins (mm)	4.1 x 5.2 (104 x 132)	Battery capacity	650CCA 850CA 115RC GROUP SIZE 24F
Nominal Power	198.5 hp		
Cooling	Liquid		
Governor	Mechanical		
Governor Regulation Class	ISO 8528 Part 1 Class G3		
Frequency Regulation	Mechanical Droop, Less than 5%		
Starting Motor & Alternator	12 Volt		
Compression Ratio	17.5:1		
Air Cleaner Type	Heavy duty - single cartridge		
ALTERNATOR SPECIFICATION			
Manufacturer	STAMFORD		
Model 120/240V Single phase	UCI274D		
Model 120/208V Three phase	UCI274D		
Model 277/480V Three phase	UCI274C		
Model 347/600V Three phase	UCI274D		
Alternator Type	Four pole, rotating field		
Excitation System	Brushless		
Power Factor	0.8		
Number of Leads	12 leads, reconnectable		
Stator Pitch	2/3		
Insulation	Class H		
Windings – Temperature Rise	Class H (125/40° C)		
Enclosure (IEC-34-S)	IP23		
Bearing	Single, sealed		
Coupling	Flexible disc		
Amortisseur Windings	Full		
Voltage Regulation – No load to full load with MX341 AVR	± 1%		
TIF	<50		
Radio Frequency Emissions Compliance	Meets requirements of most industrial and commercial applications		
Line Harmonics	5% maximum		

## STANDARD FEATURES

ENCLOSURE (If selected)	ENGINE SYSTEM	FUEL SYSTEM
Rust-Proof Fastener with Nylon Washers Protect Finish	Oil Drain Extension	Primary Fuel Filter
High Performance Sound-Absorbing Material (L1)	Air Cleaner	Flexible Fuel Lines
Gasketed Doors	Fan Guard	GENERATOR SET
Air Discharge Hoods for Radiators- Upwards Pointing	Factory Filled Oil	Separation of Circuits – Multiple Breakers (load center)
Lift Off Door Hinges	Battery Charging Alternator	Separation of Circuits – High / Low Voltage
Stainless Steel Lockable Handles	ALTERNATOR SYSTEMS	Internal Genset Vibration Isolation
Textured Polyester Powder Coat	12 Leads (3-Phase, Non 600V)	Wrapped Exhaust Piping
COOLING SYSTEM	Class H Insulation Material	Standard Factory Testing
Factory-Installed Radiator	Vented Rotor	2 Year/2000 Hours Limited Warranty
Radiator Drain Extension	2/3 Pitch	Emergency Stop
50/50 Ethylene Glycol Antifreeze	Full Load Capacity Alternator	Silencer Mounted in the Discharged Hood (Enclosed Only)
ELECTRICAL SYSTEMS	Protective Thermal Switch	
Battery Cables and Battery Tray	Permanent Magnet Excitation	
Batteries	Skewed Stator	

## CONTROL SYSTEM



- Charge alternator failure alarm
- 4-Line back-lit LCD text display
- Front panel editing with PIN protection
- Customizable status screens
- Power save mode
- 11 configurable inputs
- 8 configurable outputs
- Flexible sensor inputs
- Configurable timers and alarms
- 3 configurable maintenance alarms
- Multiple date and time scheduler
- Configurable event log (250)
- Configurable MODBUS pages
- Fully configurable via DSE Configuration Suite PC Software
- Data logging to assist with fault finding

- “Protections disabled” feature
- kW protection
- Reverse power (kW) protection
- LED and LCD alarm indication
- Power monitoring (kWh, kVA, kVAh, kVArh)
- Load switching (load shedding and dummy load outputs)
- Independent Earth Fault trip
- Fuel usage monitor and low fuel alarms
- Configurable display languages
- User selectable simultaneous RS232, RS485 & Ethernet communications
- MODBUS RTU & TCP support
- License-free PC software
- Multiple date and time scheduler
- DSENet® expansion compatible
- PLC editor allows user configurable functions to meet specific applications requirements.

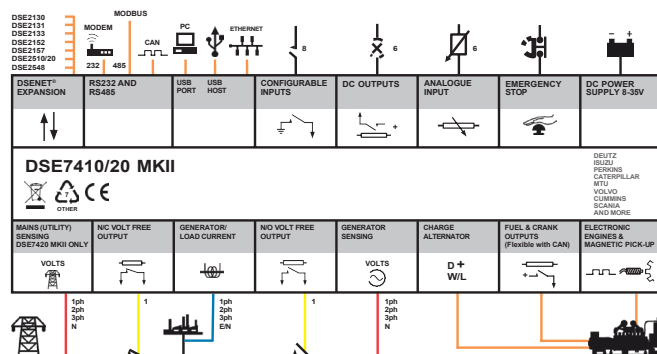

## CONFIGURABLE OPTIONS

ENCLOSURE	ENGINE SYSTEM	ELECTRICAL SYSTEM
Open Skid	Oil Heater	Battery Warmer
Level 1 Sound Attenuation	120V-1ph Water Jacket Heater (with Isolation Valves)	10A Battery Charger
Level 2 Sound Attenuation	208V-3ph Water Jacket Heater (with Isolation Valves)	6A Battery Charger
Level 1 Sound Attenuation (Aluminum Enclosure)	<b>CIRCUIT BREAKER OPTIONS</b>	10 Positions Load Center (100Amps)
Level 2 Sound Attenuation (Aluminum Enclosure)	Auxiliary Contacts for Main & Secondary Breaker	Remote ESTOP with N3R break glass
<b>ALTERNATOR SYSTEM</b>	Thermal-Magnetic Trip 80% & 100% Rated	120V GFCI Receptacle
Anti-Condensation Heater	LS/I Electronic Trip 80% and 100% Rated	10A Relay Common Alarm
Alternator Up-Sizing	LSI Electronic Trip 80% and 100% Rated	10A Run Relay
Rheostat	LSIG Electronic Trip 80% and 100% Rated	8 LED Remote Annunciator on Surface Mounted Box
MX321AVR	Second Main Line Circuit Breaker	16 LED Remote Annunciator on Surface Mounted Box
<b>CERTIFICATIONS</b>	Mechanical Lugs	24 LED Remote Annunciator on Surface Mounted Box
IBC Certification	Shunt Trip	<b>GENERATOR SET</b>
		Extended Factory Load Testing
		Extended Warranty
		Seismic Mounts

## ENGINEERED OPTIONS

ENCLOSURE	ENGINE SYSTEM	ELECTRICAL SYSTEM
Snow Hood (Only with L2)	Fluid Containment Pan	AC/DC Enclosure Lighting Kit with Timer
Air Outlet Gravity Dampers	<b>CONTROL SYSTEM</b>	Enclosure Heater
Air Inlet Motorized Dampers (Only with L2)	Spare inputs (x4) / output (x4)	240V Twist Lock Receptacle
<b>CIRCUIT BREAKER OPTIONS</b>	DSE2130 - DSENet Input Expansion Module	<b>GENERATOR SET</b>
3rd Breaker System	DSE2157 - DSENet Output Expansion Module	Special Testing
Shunt Trip on 3rd Breaker	DSE855 - DSENet USB to Ethernet ModBus TCP/IP Communication Module	<b>ALTERNATOR SYSTEM</b>
Auxiliary Contact on 3rd Breaker	DSE892 - DSENet USB to Ethernet ModBus TCP/IP - SNMP Comm. Module	Tropical Coating
<b>FUEL TANK</b>	DSE2520 - Remote Display Module	
Custom Size – 72hr and 96hr		
Custom Type to Meet State Spec.		
Vent Extensions		
Overfill Protection Valve		

## OPERATING DATA

FUEL SYSTEM		
Recommended Fuel	# 2 - ULSD	
Fuel Supply Line, Min. ID mm(in.)	9.5 - (3/8")	
Fuel Return Line, Min. ID, mm (in.)	9.5 - (3/8")	
Max. Lift, Fuel Pump, Type, m (ft)	TBD	
Fuel Filter	Secondary 5 Microns @ 98% Efficiency	
FUEL CONSUMPTION		(Standby Power Rating)
100% Load	US Gal/hr (L/hr)	7.8 (29.5)
75% Load	US Gal/hr (L/hr)	5.7 (21.6)
50% Load	US Gal/hr (L/hr)	2.9 (11)
25% Load	US Gal/hr (L/hr)	1.45 (5.5)
COOLING SYSTEM		
Engine Cooling Air Flow	cfm (m <sup>3</sup> /min)	8,052 (228)
Alternator Cooling Flow	cfm (m <sup>3</sup> /min)	1,307 (37)
Combustion Air Flow	cfm (m <sup>3</sup> /min)	389 (11)
Total Cooling Air Flow (Engine + Alternator + Combustion)	cfm (m <sup>3</sup> /min)	9,748 (276)
Total Cooling Capacity	US gallons (liters)	3.96 (15)
Max. Operating Temperature	°F (°C)	122 (50)
EXHAUST		
Exhaust Gas Flow	cfm (m <sup>3</sup> /min)	782 (22.1)
Max. Exhaust Temp at Full Load Degrees	°F (°C)	896 (480)
Max. Permissible Back Pressure	in H2O (kPA )	20 (5)

## STARTING CAPABILITIES (sKVA)

	120/240V (1PH)					277/480V					208/240V					347/600V				
ALTERNATOR	10%	15%	20%	25%	30%	10%	15%	20%	25%	30%	10%	15%	20%	25%	30%	10%	15%	20%	25%	30%
STANDARD	75	120	170	225	290	90	140	200	265	340	110	175	250	330	420	110	175	250	335	430
UP-SIZED	70	110	160	210	270	110	175	250	330	420	115	180	260	350	440	115	185	260	350	450

## CIRCUIT BREAKER

	120/240V (1PH)		277/480V		120/208V		120/240V		347/600V	
MAKE & MODEL	ABB XT5NU360BBFF000XXX		ABB XT4NU3150AFF000XXX		ABB XT5NU340ABFF000XXX		ABB XT5NU330ABFF000XXX		ABB XT2NU3125BFF000XXX	
AMPS	600 A		150 A		400 A		300 A		125 A	

# DIMENSIONS, WEIGHTS & SOUND LEVELS

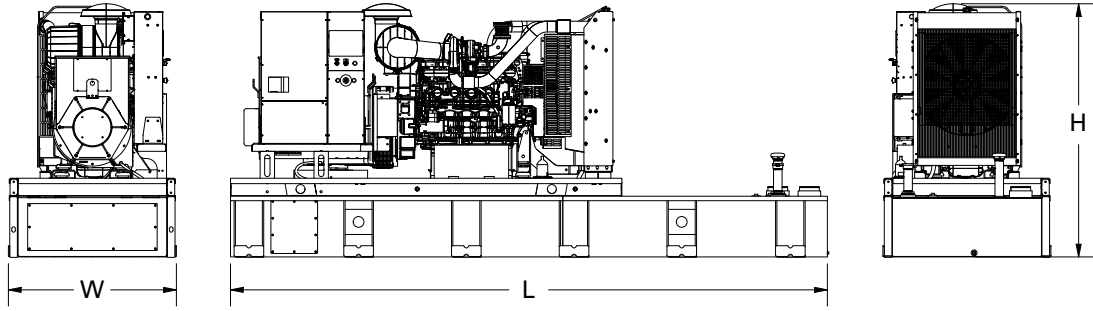

CONFIGURATION	RUN TIME (HOURS)	USABLE CAPACITY (Gal.)	L = Length	W = Width	H = Height	Weight lbs	dBA
OPEN SET	No Tank	-	109"	46.3"	54"	3,120	N/A
	42	320	167"	46.7"	71"	4,621	
	83	640	167"	46.7"	85"	5,200	

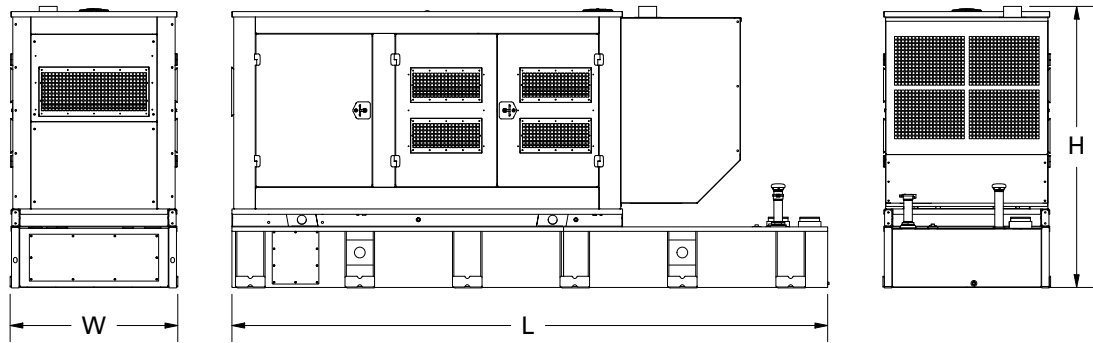

CONFIGURATION	RUN TIME (HOURS)	USABLE CAPACITY (Gal.)	L = Length	W = Width	H = Height	Weight lbs	dBA
LEVEL 1 ENCLOSURE	No Tank	-	142.1"	46.3"	60.1"	4,520	74
	42	320	167"	46.7"	78.1"	6,021	
	83	640	167"	46.7"	92.2"	6,620	

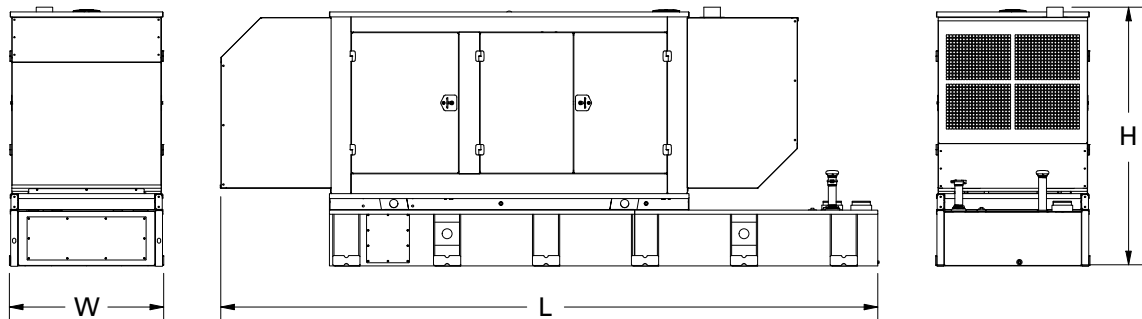

CONFIGURATION	RUN TIME (HOURS)	USABLE CAPACITY (Gal.)	L = Length	W = Width	H = Height	Weight lbs	dBA
LEVEL 2 ENCLOSURE	No Tank	-	175.2"	46.3"	60.1"	4,620	72
	42	320	199.1"	46.7"	78.1"	6,121	
	83	640	199.1"	46.7"	92.2"	6,720	

\* All measurements are approximate and for estimation purposes only. Weights are without fuel tank. Sound levels measured at 23ft (7m) and does not account for ambient site conditions.

\*\* Pictures above are for visual representation only, may not represent options or bill of material supplied.



**Intertek**  
 4008009  
 Certified to ANSI/CAN/UL/ULC STD 2200:220Ed.3+R05Sep2025

REV 04-2026